

FEATURES

6th Order Adjustable Video Filters

36MHz, 18MHz, and 9MHz

Many video standards supported

GBR, YPbPr, YUV, SD, Y/C

DC Output Offset Adjust: $\pm 0.5V$, input referred

Fixed throughput gain of x2

Excellent Video Specifications

Wide Supply Range

+4.5V to $\pm 5V$

Rail-to-Rail Output

Disable feature

Small Packaging: 20-lead QSOP

APPLICATIONS

Set Top Boxes

DVD Players and Recorder

Personal Video Recorders

HDTV

Projectors

PRODUCT OVERVIEW

The ADA4412-3 is a comprehensive filtering solution that is carefully designed to give designers the flexibility to easily filter and drive various video signals, including high definition video. Cutoff frequencies of the 6th order video filters range from 9 MHz to 36 MHz, and can be selected by two logic pins to obtain four filter combinations that are tuned for RGB, high definition, and standard definition video signals.

The ADA4412-3 includes an output offset voltage adjustment feature. Output voltage offset is continuously adjustable over an input-referred range of ± 500 mV by applying a differential voltage to an independent offset control input.

The ADA4412-3 can operate on a single +5V supply as well as $\pm 5V$ supplies. Single supply operation is ideal in applications where power consumption is critical. A disable feature allows for further power conservation.

FUNCTIONAL BLOCK DIAGRAM

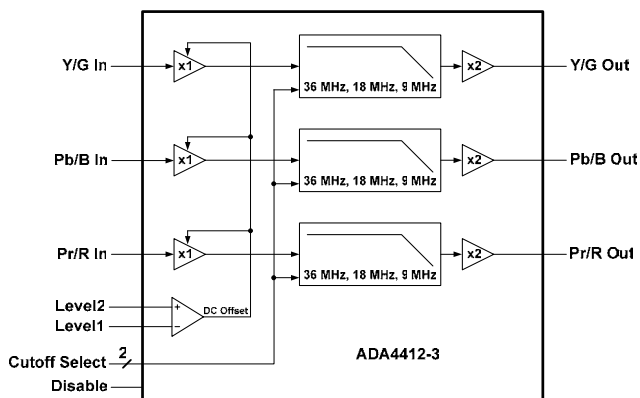

Figure 1.

Dual supply operation is best for applications where the negative-going video signal excursions must swing at or below ground while maintaining excellent video performance. The output buffers will have the ability to drive two 75 Ohm terminated loads that are either DC or AC coupled.

The ADA4412-3 is available in the 20 pin QSOP, package and is rated for operation over the commercial temperature range of -40° to +85°C.

TABLE OF CONTENTS

ADA4412-3—Specifications	3	Pin Configurations And Functional Descriptions	6
Absolute Maximum Ratings.....	5	Outline Dimensions	7
Thermal Resistance	5	ESD Caution.....	7

REVISION HISTORY

Revision History: Rev PrA Originated

04/05/2005

ADA4412-3—SPECIFICATIONS

$V_S = 5\text{ V}$, @ $T_A = 25^\circ\text{C}$, $V_O = 1.4\text{ V p-p}$, $G = \times 2$, $R_L = 150\ \Omega$, unless otherwise noted.

Table 1.

Parameter	Test Conditions/Comments	Min	Typ	Max	Unit
OVERALL PERFORMANCE					
Offset Error	Input referred, all channels		10		mV
Offset Adjust Range	Input Referred		± 500		mV
Input Voltage Range, All Inputs		$V_{S-} - 0.1$		$V_{S+} - 2.0$	V
Output Voltage Range, All Outputs	$I_O = 15\text{ mA}$, positive swing	$V_{S+} - 0.5$	$V_{S+} - 0.25$		V
	$I_O = 15\text{ mA}$, negative swing	$V_{S-} + 0.4$	$V_{S-} + 0.12$		V
Linear Output Current per Channel			30		mA
Integrated Voltage Noise, Referred to Input	All channels		500		μV_{rms}
Filter Input Bias Current	All channels		6.6		μA
Total Harmonic Distortion at 1 MHz	$f_C = 36\text{ MHz}$, $f_C = 18\text{ MHz}/f_C = 9\text{ MHz}$		0.01/0.07		%
FILTER DYNAMIC PERFORMANCE					
-1 dB Bandwidth	Cutoff frequency select = 36 MHz		30		MHz
	Cutoff frequency select = 18 MHz		15		MHz
	Cutoff frequency select = 9 MHz		8		MHz
-3 dB Bandwidth	Cutoff frequency select = 36 MHz		36		MHz
	Cutoff frequency select = 18 MHz		18		MHz
	Cutoff frequency select = 9 MHz		9		MHz
Out-of-Band Rejection	$f = 75\text{ MHz}$		-35		dB
Crosstalk	$f = 5\text{ MHz}$, $f_C = 36\text{ MHz}$		-68		dB
Propagation Delay	$f = 16\text{ MHz}$, $f_C = 36\text{ MHz}$		20		ns
Group Delay Variation	Cutoff frequency select = 36 MHz		8		ns
	Cutoff frequency select = 18 MHz		15		ns
	Cutoff frequency select = 9 MHz		26		ns
CUTOFF CONTROL INPUT PERFORMANCE					
Input Logic 0 Voltage				0.8	V
Input Logic 1 Voltage		2.0			V
Input Bias Current			7		μA
DISABLE PERFORMANCE					
DISABLE Assert Voltage			$V_{S+} - 0.5$		V
DISABLE Assert Time			100		ns
DISABLE De-Assert Time			130		ns
DISABLE Input Bias Current			12		μA
Input-to-Output Isolation—Disabled			100		dB
POWER SUPPLY					
Operating Range		4.5		12	V
Quiescent Current			60		mA
Quiescent Current—Disabled			15	150	μA
PSRR, Positive Supply	All channels		72		dB
PSRR, Negative Supply	All channels		62		dB

$V_S = \pm 5\text{ V}$, @ $T_A = 25^\circ\text{C}$, $V_O = 1.4\text{ V p-p}$, $G = \times 2$, $R_L = 150\ \Omega$, unless otherwise noted.

Table 2.

Parameter	Test Conditions/Comments	Min	Typ	Max	Unit
OVERALL PERFORMANCE					
Offset Error	Input referred, all channels		14		mV
Offset Adjust Range	Input Referred		± 500		mV
Input Voltage Range, All Inputs		$V_{S-} - 0.1$		$V_{S+} - 2.0$	V
Output Voltage Range, All Outputs	$I_O = 30\text{ mA}$, positive swing	$V_{S+} - 0.6$	$V_{S+} - 0.3$		V
	$I_O = 30\text{ mA}$, negative swing	$V_{S-} + 0.6$	$V_{S-} + 0.3$		V
Linear Output Current per Channel			30		mA
Integrated Voltage Noise, Referred to Input	All channels		500		μV_{rms}
Filter Input Bias Current	All channels		6.3		μA
Total Harmonic Distortion at 1 MHz	$f_c = 36\text{ MHz}$, $f_c = 18\text{ MHz}/f_c = 9\text{ MHz}$		0.01/0.07		%
FILTER DYNAMIC PERFORMANCE					
-1 dB Bandwidth	Cutoff frequency select = 36 MHz		28		MHz
	Cutoff frequency select = 18 MHz		15		MHz
	Cutoff frequency select = 9 MHz		8		MHz
-3 dB Bandwidth	Cutoff frequency select = 36 MHz		35.5		MHz
	Cutoff frequency select = 18 MHz		18		MHz
	Cutoff frequency select = 9 MHz		9.5		MHz
Out-of-Band Rejection	$f = 75\text{ MHz}$		-32		dB
Crosstalk	$f = 5\text{ MHz}$, $f_c = 36\text{ MHz}$		-68		dB
Propagation Delay	$f = 5\text{ MHz}$, $f_c = 36\text{ MHz}$		21		ns
Group Delay Variation	Cutoff frequency select = 36 MHz		6		ns
	Cutoff frequency select = 18 MHz		13		ns
	Cutoff frequency select = 9 MHz		23		ns
CUTOFF CONTROL INPUT PERFORMANCE					
Input Logic 0 Voltage				0.8	V
Input Logic 1 Voltage		2.0			V
Input Bias Current			7		μA
DISABLE PERFORMANCE					
DISABLE Assert Voltage			$V_{S+} - 0.5$		V
DISABLE Assert Time			75		ns
DISABLE De-Assert Time			125		ns
DISABLE Input Bias Current			35		μA
Input-to-Output Isolation—Disabled			100		dB
POWER SUPPLY					
Operating Range		4.5		12	V
Quiescent Current			63		mA
Quiescent Current—Disabled			15	150	μA
PSRR, Positive Supply	All channels		72		dB
PSRR, Negative Supply	All channels		62		dB

ABSOLUTE MAXIMUM RATINGS

Table 3. ADA4412-3 Absolute Maximum Ratings

Parameter	Rating
Supply Voltage	12V
Power Dissipation	See Figure 2
Storage Temperature	-65°C to +125°C
Operating Temperature Range	-40°C to +85°C
Lead Temperature Range (Soldering 10 sec)	300°C
Junction Temperature	150°C

Stresses above those listed under Absolute Maximum Ratings may cause permanent damage to the device. This is a stress rating only and functional operation of the device at these or any other conditions above those indicated in the operational section of this specification is not implied. Exposure to absolute maximum rating conditions for extended periods may affect device reliability.

THERMAL RESISTANCE

θ_{JA} is specified for the worst-case conditions, i.e., θ_{JA} is specified for device soldered in circuit board for surface mount packages.

Table 4. Thermal Resistance

Package Type	θ_{JA}	θ_{JC}	Unit
20 Lead QSOP	83		°C/W

Maximum Power Dissipation

The maximum safe power dissipation in the ADA4412-3 package is limited by the associated rise in junction temperature (T_J) on the die. At approximately 150°C, which is the glass transition temperature, the plastic changes its properties. Even temporarily exceeding this temperature limit may change the stresses that the package exerts on the die, permanently shifting the parametric performance of the ADA4412-3. Exceeding a junction temperature of 150°C for an extended period of time can result in changes in the silicon devices potentially causing failure.

The power dissipated in the package (P_D) is the sum of the quiescent power dissipation and the power dissipated in the package due to the load drive for all outputs. The quiescent power is the voltage between the supply pins (V_S) times the quiescent current (I_S). The power dissipated due to load drive depends upon the particular application. For each output, the power due to load drive is calculated by multiplying the load current by the associated voltage drop across the device. The power dissipated due to all of the loads is equal to the sum of the power dissipations due to each individual load. RMS voltages and currents must be used in these calculations.

Airflow increases heat dissipation, effectively reducing θ_{JA} . Also, more metal directly in contact with the package leads from metal traces, through-holes, ground, and power planes reduces the θ_{JA} .

Figure 2 shows the maximum safe power dissipation in the package vs. the ambient temperature for the 20-lead QSOP (TBD°C/W) on a JEDEC standard 4-layer board. θ_{JA} values are approximations.

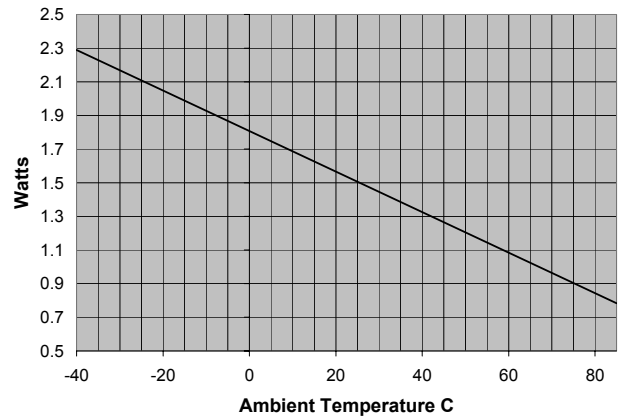

Figure 2. Maximum Power Dissipation vs. Temperature for a 4-layer board

PIN CONFIGURATIONS AND FUNCTIONAL DESCRIPTIONS

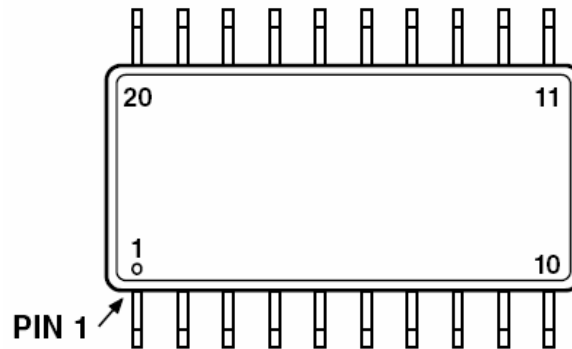

Figure 3. 20-Lead QSOP

Table 5. Pin Function Descriptions—
20-Lead QSOP (RQ-20 PACKAGE)

Pin No.	Name	Description
1	LEVEL1	DC Level Adjust Pin 1
2	DISABLE	Disable/Power Down
3	Y/G	Y/G High Definition Input
4	GND	Signal Ground Reference
5	Pb/B	Pb/B High Definition Input
6	GND	Signal Ground Reference
7	Pr/R	Pr/R High Definition Input
8	F_SEL_A	Filter Cutoff Select Input A
9	F_SEL_B	Filter Cutoff Select Input B
10	GND	Signal Ground Reference
11	DGND	Digital Ground Reference
12	NC	No Internal Connection
13	VCC	Positive Power Supply
14	Pr/R_OUT	Pr/R High Definition Output
15	VEE	Negative Power Supply
16	Pb/B_OUT	Pb/B High Definition Output
17	VEE	Negative Power Supply
18	Y/G_OUT	Y/G High Definition Output
19	VCC	Positive Power Supply
20	LEVEL2	DC Level Adjust Pin 2

OUTLINE DIMENSIONS

20-Lead Shrink Small Outline Package [QSOP]
(RQ-20)
Dimensions shown in inches

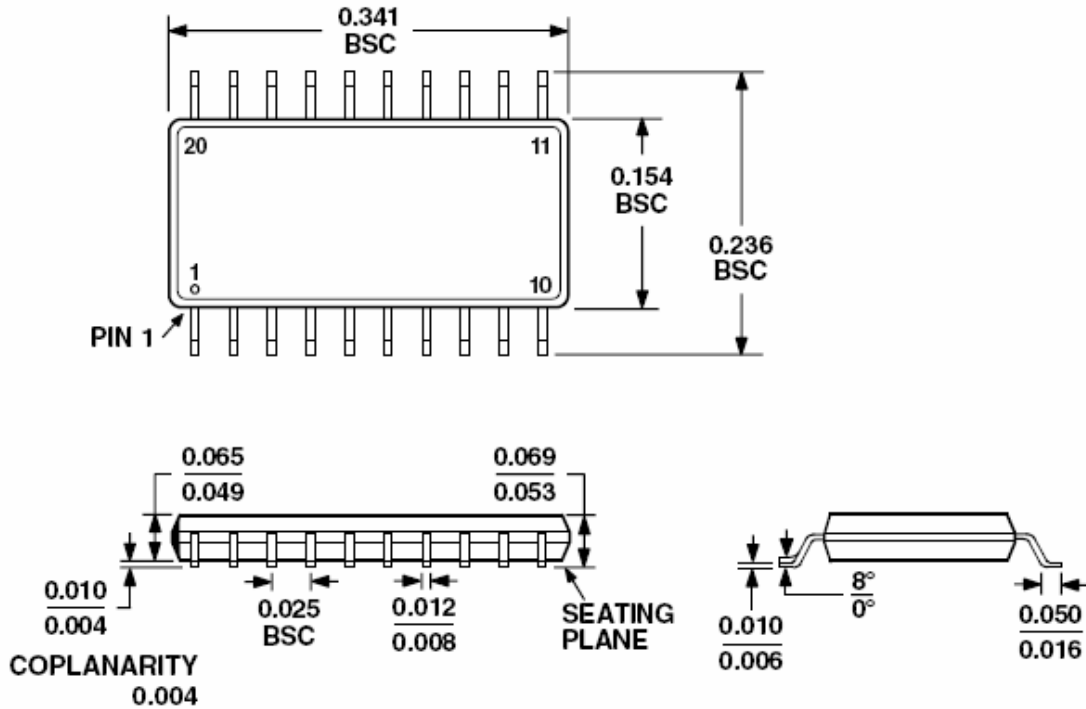

COMPLIANT TO JEDEC STANDARDS MO-137AD

Figure 4. 20-Lead Small Outline Package [QSOP] (RQ-20)—Dimensions shown in inches

ESD CAUTION

ESD (electrostatic discharge) sensitive device. Electrostatic charges as high as 4000 V readily accumulate on the human body and test equipment and can discharge without detection. Although this product features proprietary ESD protection circuitry, permanent damage may occur on devices subjected to high energy electrostatic discharges. Therefore, proper ESD precautions are recommended to avoid performance degradation or loss of functionality.



Table 6. Ordering Guide

ADA4412 Products	Temperature Range	Package Description	Package Outline
ADA4412-3ARQZ	-40°C to +85°C	20-Lead QSOP	RQ-20
ADA4412-3ARQZ-REEL7	-40°C to +85°C	20-Lead QSOP	RQ-20
ADA4412-3ARQZ-REEL	-40°C to +85°C	20-Lead QSOP	RQ-20